

Smart Agriculture System Using IoT

Kishor Kumar R¹, Manjunath B Kajjidi² and Pradeep Kumar M S³

¹Don Bosco Institute of Technology/Department of Telecommunication, Bangalore, India
Email: kishor13kumar@gmail.com

²⁻³Don Bosco Institute of Technology/Department of Telecommunication, Bangalore, India
Email: { manju029@gmail.com, pradeepreddyindu@gmail.com }

Abstract— Agriculture plays a crucial role in the life of an economy. It is the backbone of our economic system. Agriculture not only provides food and raw material but also employment opportunities to a very large proportion of population. The manual collection of data and human intervention in the field is labour intensive. Automation of data collection at regular and frequent interval reduces labour requirement and cost. The aim of this work is introduce a system to collect field data at regular and frequent interval and to reduce manual labour with the help of Raspberry-Pi IoT based system for effective collection and process all data, information transfer, Make decisions and provide automation and control function for efficient and cost effective crop yielding.

I. INTRODUCTION

Agriculture plays a crucial role in the life of an economy. It is the backbone of our economic system. Agriculture not only provides food and raw material but also employment opportunities to a very large proportion of population. The manual collection of data and human intervention in the field is labour intensive. Automation of data collection at regular and frequent interval reduces labour requirement and cost. The aim of this work is introduce a system to collect field data at regular and frequent interval and to reduce manual labour with the help of Raspberry-Pi IoT based system for effective collection and process all data, information transfer, Make decisions and provide automation and control function for efficient and cost effective crop yielding. By 2050, it is predicted that the world's population would reach 9.2 billion , 34% higher than today. Much of this growth will happen in developing countries like India, Brazil, which has the largest area in the world with suitable land for agriculture. To match with the rising populations and income growth, global food production must increase by 70% in order to be able to feed the world. Ms.DeweshreeRane, Prof. P. R. Indurkar and Prof. D. M. Khatri proposed a review paper on Smart Irrigation System which is "Review paper based on automatic irrigation system based on RF module"[1]. In this paper, soil moisture sensor, temperature sensors placed in root zone of plant and gateway unit handles the sensor information and transmit data to a web application. In "GSM Based Automated Irrigation Control using Rain gun Irrigation System".R.suresh , S.Gopinath , K.Govindaraju , T.Devika , N.Suthanthira Vanitha[2] mentioned about using automatic microcontroller based rain gun irrigation system in which the irrigation will take place only when there will be intense requirement of water that save a large quantity of water. These system address lower range of irrigation land and not economically affordable. All the project and solution mentioned above uses microcontroller, in our project we are using Raspberry-pi 3 SOC board and an array of sensors to implement irrigation automation which includes moisture monitoring of crops, water level monitoring, motion detection and automatic electric fence control. The Raspberry-Pi is a series of single-board computers developed in the United Kingdom by the Raspberry Pi Foundation with the intent to

promote the teaching of basic computer science in schools and developing countries. All models feature a Broadcom system on a chip (SOC), which includes an ARM compatible CPU and an on chip graphics processing unit GPU (a Video-Core IV). CPU speed ranges from 700 MHz to 1.2 GHz for the Pi 3 and on board memory range from 256 MB to 1 GB RAM. Secure Digital SD cards are used to store the operating system and program memory in either the SDHC or Micro-SDHC sizes. Most boards have between one and four USB slots, HDMI and composite video output, and a 3.5 mm phone jack for audio. IoT (Internet of Things) is a technology idea and an architecture which is a collection of available technologies. Similar to the way in which Internet has changed the way of working and communicate by connecting humans through Web, IoT is intended to take this connectivity to next level by connecting various devices to the internet – facilitating human-machine, machine-machine interactions also, The IoT ecosystem has business applications in areas of Home Automation, Automotive, Factory/assembly line automation, Retail, Medical/Preventive healthcare and more.

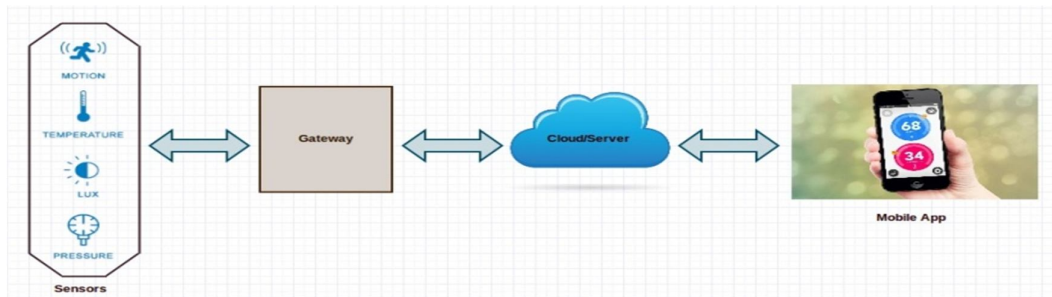

Figure 1. Block diagram of IOT

II. SYSTEM DESIGN

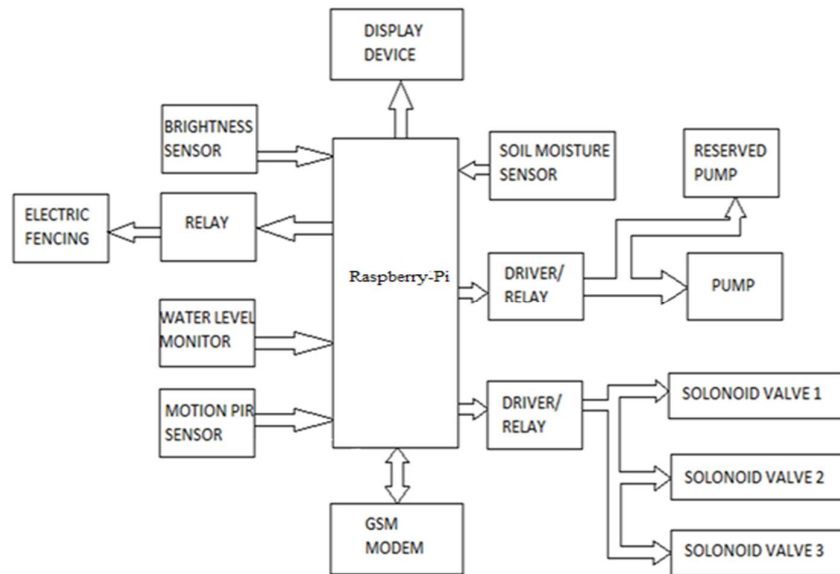

Figure 2. Block diagram of smart agriculture system

In this work low cost soil moisture sensors and humidity sensors, are used. They continuously monitor the field. Most soil moisture sensors are designed to estimate soil water content based on the dielectric constant (soil bulk permittivity) of the soil. The dielectric constant can be thought of as the soil's ability to transmit

electricity. The dielectric constant of soil increases as the water content of the soil increases. This response is due to the fact that the dielectric constant of water is much larger than the other soil components, thus, measurement of the dielectric constant gives a predictable estimation of water content. Thus this measurement is used to control water pump to fill the water tank or to turn on the sprinklers to water the crops. The soil moisture sensor has two probes which is inserted into the soil. The probes are used to pass current through the soil. The moisture soil has less resistance and hence passes more current through the soil whereas the dry soils has high resistance and pass less current through the soil. The resistance value help detecting the soil moisture.

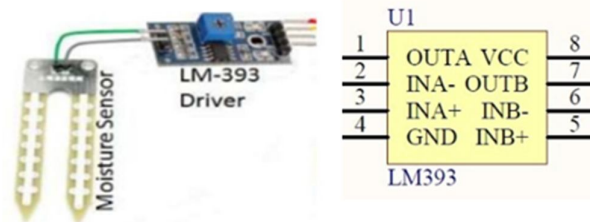

Figure 3. Soil moisture sensor

Light sensor is used to detect light intensity of the environment. Light Dependent Resistor (LDR) is used in which the resistivity decreases with increase in light intensity and vice versa. The voltage divider circuit is designed to measure resistance due to light intensity variations. The voltage level increases with increase in light intensity. A light dependent resistor works on the principle of photo conductivity. Photo conductivity is an optical phenomenon in which the materials conductivity is increased when light is absorbed by the material. When light falls i.e. when the photons fall on the device, the electrons in the valence band of the semiconductor material are excited to the conduction band. These photons in the incident light must have energy greater than the band gap of the semiconductor material to make the electrons jump from the valence band to the conduction band. Hence when light having enough energy strikes on the device, more and more electrons are excited to the conduction band which results in large number of charge carriers. The result of this process is more and more current starts flowing through the device when the circuit is closed and hence it is said that the resistance of the device has been decreased. This is the most common working principle of LDR. LDR is used as sensor to turn on and off electric fence or provide artificial lighting for plantation of necessary.

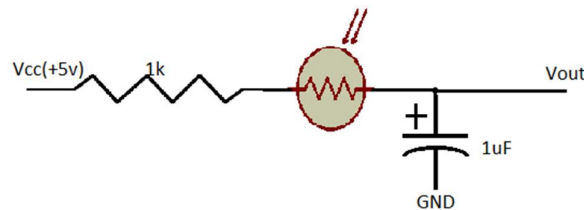

Figure 3. LDR circuit

We use PIR sensors for motion detection, If a motion is detected by the PIR sensor, we take the picture of the region and send it to the email of the farmer, where it could be viewed, The boundaries of the farm would be installed with PIR sensor, The snaps taken can also be used to monitor animal intrusion in to the form. The PIR sensor with 3 pin connection is as shown in figure.

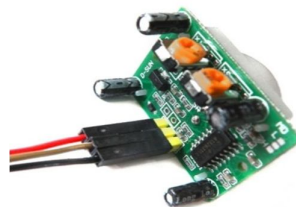

Figure 4. 3-pin PIR sensor

We use Python language for programming of Raspberry pi. Python language is a high level, general purpose coding language. Most importantly it is simple to understand and easy to code. Any other coding language compatible with raspberry pi can also be used. Open CV is installed on raspberry pi 2 for the purpose of image detection

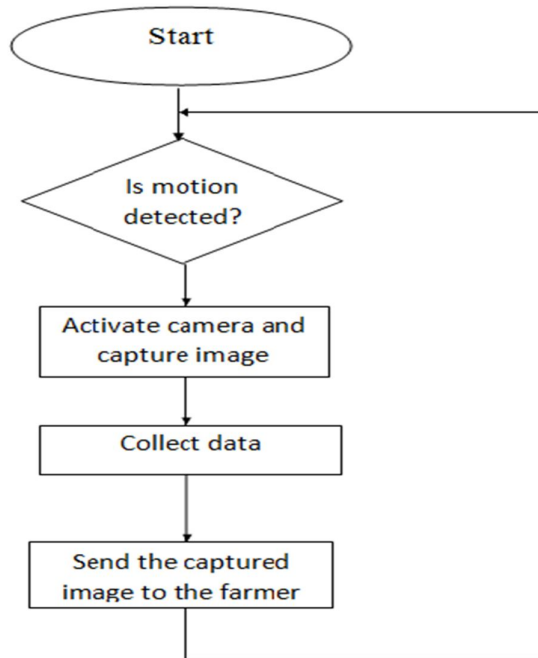

Figure 5. Flow diagram for motion detection and image capture.

III. FUTURE SCOPE

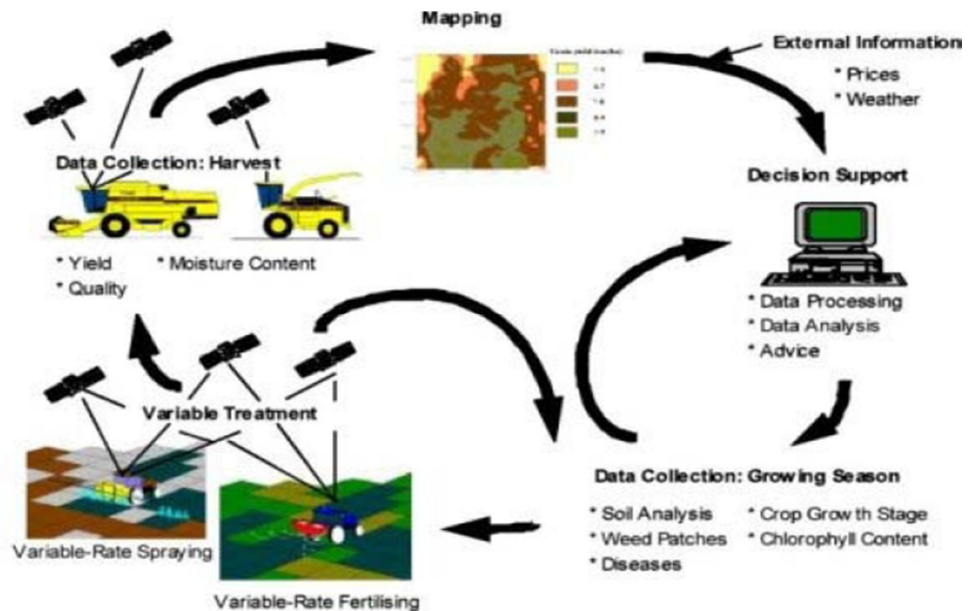

Figure 6. Schematics of a possible future management process for a modern farm

In the near future, a modern day agriculture farm could be managed as shown in Figure 6. Based on data from each field, such as rotation of the crop, yield of the crop, soil condition, amount of infestation spread, and conditions of climate where crops are grown, decision models would determine the site specific soil tillage, pretreatment of the seedbed, and sowing density of the farm. In the growth season, the modern farmer decides about site-specific application of fertilizers, supported by crop growth models and field measurements, the most important of which is soil coverage of crops in the early growth stage. A spraying machine aided with optical sensors for detection of diseases and weeds is used for the treatment of the crops. During harvesting, sensors monitor the bulk mass flow of harvested raw produce in the harvesting machine and also product properties that are valued commercially such level of protein and moisture content of cereals and sugar content of sugar beets. These data, related to the field where it is captured and position of the machine are mapped in the records to support site-specific crop management in subsequent growing season.

IV. CONCLUSION

The smart agriculture system using IoT has been designed and implemented in this paper. The system developed is beneficial and works in cost effective manner. It reduces the water consumption to a great extent. It reduces the maintenance, the power consumption could be reduced by using solar power. The system can be used in green houses. The System is very useful in areas where water availability is a major problem. The productivity of the crop increases and the wastage of crops is very much reduced using this agriculture system. The developed system is more helpful and gives more feasible results.

V. ACKNOWLEDGEMENT

The authors immensely thankful to DBIT, Bangalore, India for the full support given to carry out this research work.

REFERENCES

- [1] Review paper based on automatic irrigation system based on RF module: Ms Deweshvree rane, volume 1, issue 9, 2015-IJAICT.
- [2] GSM based automated irrigation control using raingun irrigation system, R. Suresh vol 3, issue 2 feb-2014, IJRCCCE.
- [3] Sensor data collection and irrigation control on vegetable crop using smart phone and wireless network for smart farm: Kaewmard N, Saiyod S, 2014 IEEE.
- [4] Smart farming system using sensor for agriculture task automation: Dwarkani M C, Ram R G, Jagannatham S, Priyatharshini R, 2015 IEEE.
- [5] Sensor data collection and irrigation control on vegetable crop using smart phone and wireless network for smart phone: SatishKannan K, Thilagavathi G, 2013 IEEE.
- [6] Joaquín Gutiérrez, Juan Francisco Villa-Medina, Alejandra Nieto-Garibay, and Miguel Ángel Porta-Gándara "Automated Irrigation System Using a Wireless Sensor Network and GPRS module", IEEE Transactions On Instrumentation And Measurement, Vol. 63, No. 1, January 2014.
- [7] Stefanos A. Nikolidakis, Dionisis Kandris, Dimitrios D. Vergadoschristos Douligeris A "Energy Efficient Automated Control Of Irrigation In Agriculture By Using Wireless Sensor Networks, Computers And Electronics In Agriculture "0168- 1699/ 2015 Elsevier B.V.
- [8] Venkata Naga Rohit Gunturi, "Micro Controller Based Automatic Plant Irrigation System" International Journal of Advancements in Research & Technology, Volume 2, Issue- 4, April-2013.